



Leeky Seel

Corvair

September 2022



Corvair Minnesota Newsletter

President's message:

Road Construction, I'm so tired of it! I had to run errands the other day and all three main roads going north were under construction, Aahhh, well I guess I didn't want to go anywhere that day anyway!!!!!! Now it's a guessing game as to what roads to take when we go out...

I'm sorry I missed the August meeting, but it was left in very good hands. Thank you to Gary Nelson and all who helped out.

Elections are coming up. Openings are:

- Activities Director
- Director at large
- Treasurer

Think about your choices

The September meeting is on the 13th at Ideal Hall. Remember, the kitchen closes at 630.

President Tom
Tom Quinn

Birthdays this month:

September Birthdays

- Floyd Ackley
- Chris Hefty
- Alexandra Howes
- Terry Quesnel
- Gail Quinn
- Paul Schuler
- Ray Willett



Happy Birthday to you!



As always, let me know if I have missed your name on the Birthday list
Thanks! Gailquinn263@msn.com (Gail Quinn, Director of Treats)

Corvair Minnesota, Club Information

Meeting minutes

August 9, 2022

Vice President Gary Nelson called the meeting to order at 7:04 pm.

22 members

New Members

CJ Pappas w/ 1961 8 door Greenbrier

Planned: October 22nd CMI breakfast meeting.

Election's are coming up... Secretary, Treasurer, Activities Director, Director... In order for the election's to proceed, we will need a nomination meeting chosen by the board. At the time of the vote, someone can be nominated. We can publish the report in October. November we will have the election.

Jim Brandberg, Activities...

Jim's goal is to find 1 or 2 car shows/events a month in different areas. Our previous shows were Prior Lake, Mankato, Saint Francis, as well as Anoka.

Upcoming car shows.

August 13th is Buffalo, New London to New Brighton.

September 10th Osceola Wheels and Wings.

October 8th is the Frankensteiner's Ball at Isanti Fairgrounds.

The Breakfast Club is scheduled for October 22nd.

Gary Nelson did a tech session regarding windshield wipers.

Car's in attendance:

5 Early Models, 3 Late Models, 2 FC's.

#7 Paul Schuler's number was called for the drawing!

Meeting adjourned at 7:39

Amber Leah

Amber Leah
CMI Secretary

Current CMI Officers Coordinators and Directors

OFFICERS

President

Tom Quinn
Tquinn1979@msn.com
(C) 612-670-9224

Vice President

Gary Nelson
corvairnelson@gmail.com
(C) 612-644-1258

Secretary

Amber Leah
amber.81.leah@gmail.com
(C) 612-251-9498

Treasurer

Lee Knauf
vairy69@comcast.net
(C) 952-826-9677

COORDINATORS

Technical Editor

Fran Schmit
schmfran@hotmail.com
(C) 952-9174

Club Wear Coordinator

Bob Kaczke
bkaczke@gmail.com
(C) 612-916-8769

SEEL Editor

John Herkenratt
jherken1@netzero.net
(C) 612-719-4580

Member Coordinator

Mike Jenkins
rockinracer@hotmail.com
(C) 763-355-0168

BOARD OF DIRECTORS

1 year

Ron Scott
risk1s@aol.com
(C) 612-600-0360

2 Year

Dave Pedersen
dave14957@gmail.com
(C) 612-385-2241

Activities

Jim Brandberg
jimbrandberg@aol.com
(C) 763-444-9334



You Can Plan Things

The Antique Car Run lunch in Buffalo and Nowthen Threshing Show both had 6 Corvairs in attendance with Early, Late and FC examples present. In Buffalo they had a visible spot and were sporting our Corvair flag. The event volunteers at Nowthen reserved the best area up front for us, I bet Mike Manthe had something to do with that and it's much appreciated. It shouldn't be surprising that everyone loves us everywhere we go, we are not the usual thing. It's always been said that the CMI Activities Director doesn't have to go to all the activities but merely help coordinate and promote. I'm living proof of that concept since I missed them both this month, although I do have good excuses all lined up. I especially wanted to see Nowthen.

The next event I'd like to promote is Osceola Wheels and Wings on Saturday September 10. I plan to be there and will probably park towards the east side. It's a big event with lots of aircraft and cars, good things to eat and books from Classic Motorbooks. I saw a Corvair powered Pietenpol Air Camper one year. Floyd Ackley says there's a car show in Pine City that day too. After that I'd like to suggest Frankensteiners Ball on Saturday October 8 at the Isanti County Fairgrounds in Cambridge. It's gotten huge so it's best to preregister and get there early. It's a Halloween theme and a nice gesture to bring candy for trick or treaters.

I've made my reservation for the 2023 CORSA Convention in Wisconsin Dells. The regular rate for a 2 Queens or 1 King plus a sofa room is \$222, we have a CORSA rate of \$129. They charge your card for one night now but that is refundable if you change your mind. For the convention, Monday June 19 is an informal arrival date and Saturday June 24 is an informal car show date, with the main convention activities Tuesday through Friday. The Chula Vista Resort is across the river and a little north from downtown Wisconsin Dells. The shortest way to get there from the Twin Cities is to get off I-90/94 at Mauston to cross the river and continue south. There is a water park at the resort. There's other places to stay but they might be a few miles away so getting a reservation early at the negotiated rate is the way to go in my view. I may have other family with children coming from New York who are not Corvair enthusiasts but there's a lot to do in Wisconsin Dells. My favorite thing is a Dells tourist boat ride on the river.

We've been working on my next daily driver, a '60 4-door 700 80 HP PG. It's just the sort of Corvair that no one was saving back in the day. I got it from the original owner in 2015 before he passed and never did meet him, only talked to him on the phone in the rest home. It's got some rust through and wouldn't be a good candidate for restoration but the Tasco Turquoise is still quite fetching. We've patched a few holes to make it structurally sound but won't be doing too much cosmetically, just mechanical. The gas tank got the Tank Renu treatment and I also had a 61-69 tank done that I can bring for show and tell. I'm putting more into this car than it will ever be worth but it is a labor of love and I plan to get my money's worth in miles of service.

My previous daily driver for a little while anyway was a '66 convertible 140 PG in Cameo Beige. A lovely car that was around CMI 20 years ago when owned by Ken Anderson. John Herkenratt always liked that car and now it is his, already sporting 14" wheels with wire wheel covers. My daily driver last year was a '63 Van I got from Floyd Ackley in 2017. Ash always liked riding around in that Van as a child and has it now. It warms my heart to see those Corvairs running again and now residing where I believe they're supposed to be. I think the '60 is where it belongs. I'm not sure why I like it, I just do.

Jim Brandberg

Help with Electric Fuel Pump Conversion

Since the Factory Fuel Pump has been exchanged, the Fuel comes in from the front and there is no need to run all the plumbing around the back, past the GEN. The two little old Fuel Lines to the Carbs can be reversed to receive the incoming Fuel at the front of the engine. The nice Brass Tee from the old Fuel Pump can be positioned right there in the middle, to accommodate the incoming fuel. Somehow it needs a skyhook to not only hold up the Tee but those three Fuel lines as well. There is a bracket for the Vacuum Balance Tube (and the Air Filter) that can be modified to support the Fuel Tee. Here's one way to do it. Try to place the Tee a bit 'forward' of the screw that secures the Air Filter, to aid in disassembly should you ever need to do that! Soldering works for mechanical construction too, but Epoxy would hold the Tee to the bracket, as well. A prettier bracket (Red?) could also be assembled! Enjoy, *Fran*

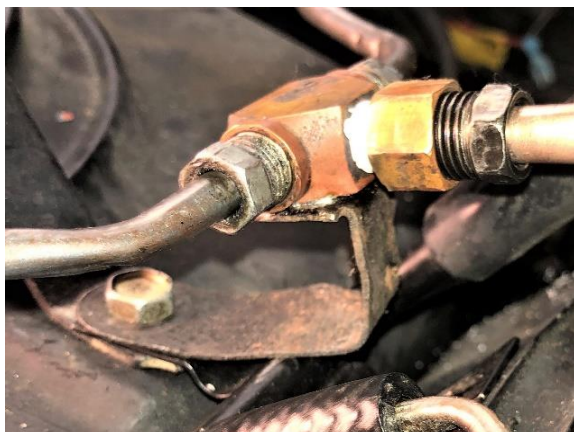
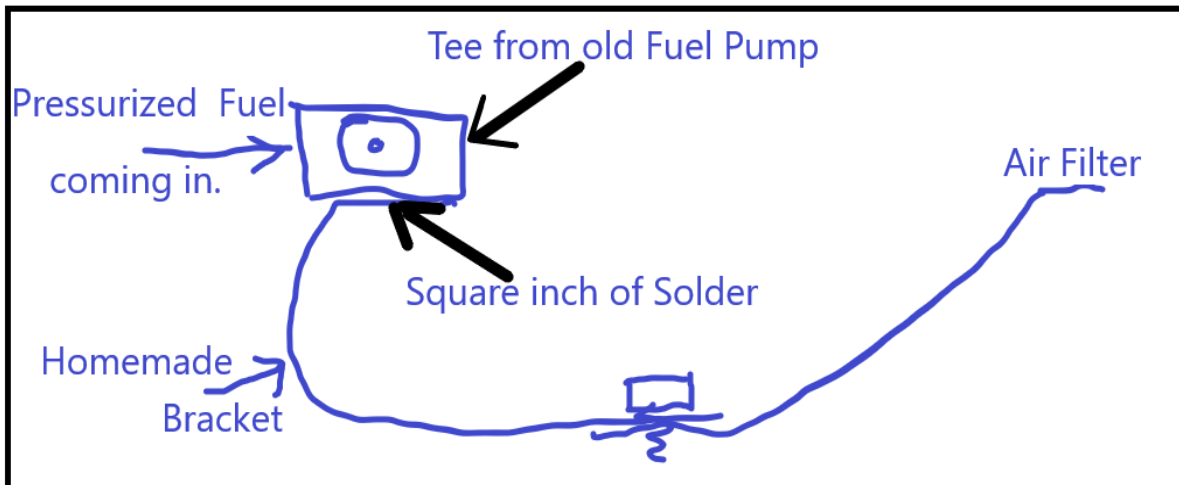

2022 Corsa convention - selected photos

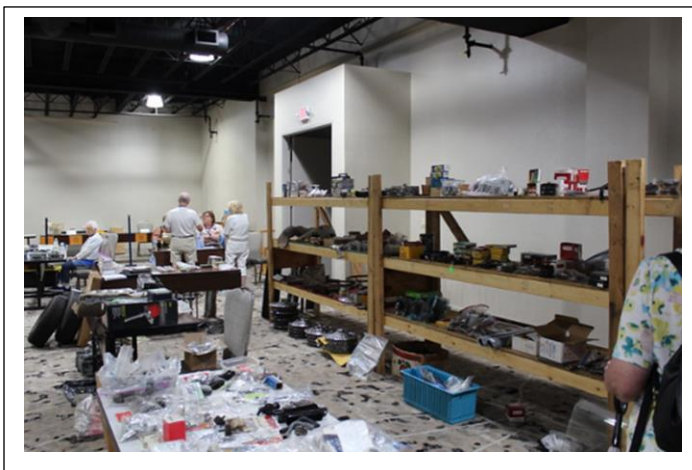

A first hand report from CMI member Paul Schuler:

My wife and I had planned on going to the Corsa Convention as soon as I found out about it. The preparation began. All moving parts were inspected. I even installed cruise control and AC. We left early to go to the NASCAR race the Sunday before the convention. I was very confident about my car.

Registration opened on Tuesday and we were there. Vendors had already set up both in the parking lot and the lower level of the registration building. Corsa and Clark's Corvair had a booth. The meet and greet was at a large plane hanger, which included supper and a speaker who was the owner of land speed Corvair, Greg Lloyd. There was an airplane with a Corvair motor in it, I don't know very much about the airplane.

There were tech sessions. Neil Johnson started at GM when he was 18. He told stories about working the line and managing the employees. Jack Green of Alabama had a kit to install disc brakes from a Chevelle onto a Corvair. Ted Brown of Alabama showed off the fuel injection kit he developed. He brought an engine in on a trailer, removed carbs, installed his kit, and got the motor running. The AutoX was in the infield of Atlanta Motor Speedway. There was a great selection of cars from stock to V8 powered Corvairs. For \$10 you could take a few laps around the speedway.

We sat at the awards banquet with the other Minnesota Corvair members, Bob Kaczke and Bob Krueger. The awards banquet was hosted by Sam Memmolo of Sam's Garage. All the trophies for the Concours d' elegance, autoX, econo run, rally, valve cover races, model cars, and other awards were handed out. There were people who drove from Portland, Oregon so I didn't get the longest drive.

It was time to head home. We decided to leave Saturday morning and away we went. The first time we turned on the AC - nothing. We stopped at an O'Reilly Auto. The belt had broken,. I decided to put new belt on. I started the car and the compressor had locked up. That began our long, hot ride home. It rained most of Sunday which made the temperature cooler. We got 150 miles from home and the fan belt broke. A quick replacement along freeway and away we went home. Our total mileage for the trip was just over 3,000 miles.



Corvair Quiz Test your knowledge!

- 1) What did they call Corvairs before production?
- 2) Did Corvair make a right hand (side) drive?
- 3) What Country and State was the Corvair used for testing? (bonus if you know the city)
- 4) How many basic designs (types) of Corvairs were made? (bonus if you can name them)
- 5) How many years was the Greenbrier made?
- 6) Did Corvair make more than 1 truck?
- 7) Did Corvair have a motorhome?
- 8) What engine was used in the Man from UNCLE car?
- 9) What former TV Talk Show host owns a Corvair?
- 10) What Country did the first test on Corvairs?

(find answers on page 8)

Antique Auto Race (New London-New Brighton) August 13, Buffalo MN



A note from Tech Editor Fran Schmit:

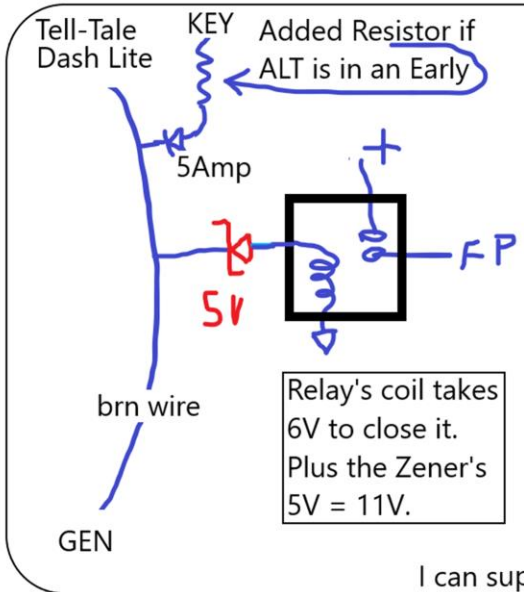

Early Model with an Alternator and Electric F.P.

If you have added the 20 ohm resistor around the Tell-Tale bulb, the voltage at the FP's relay may be too high (because of the Resistor) to activate the automatic safety shutdown that is supposed to happen in a crash.

To guarantee the shutdown will occur, add a 5V Zener Diode where it is shown, in RED. Remember to observe polarity on any diode.

In a crash the Engine has stopped so we want to be certain the FP is also quiet. The Zener Diode will mean the brn wire must be higher than 11V to turn on the FP which is a slim possibility in a crashed car with the Key still on.

I can supply any number of 5V Zener diodes - to anyone who asks. Fran

Southern Cruzers Summer Spectacular, Buck Hill, Burnsville MN, August 27th



Answers to Corvair Quiz on page 7:

1) Holden; 2) Yes; 3) Ely, Minnesota, United States; 4) 6 - Corvan, Greenbrier, Rampside, Lakewood, Early Models ('60-'64), Late Models ('65-'69); 5) 4 Years ('61-'65); 6) Yes, Rampside and Load Side; 7) No, the Ultra Van was manufactured by Ultra Van Mfg Co. but did have a Corvair engine; 8) 140 hp; 9) Jay Leno; 10) Australia

CMI 2022 Schedule

Some upcoming events, shows and cruise-ins

September

- 02-04 Rice County Steam & Gas Show, Dundas, <https://www.ricecountysteamandgas.com>
- 10 Classics by the Lake, Buffalo, 10:00 a.m. – 2:00 p.m.
- 13 **CMI** Membership meeting – **Ideal Hall, 1494 Dale St, St Paul**

October

- 02 Roadsters Swap meet, State Fairgrounds, 5:00 a.m. – 4:30 p.m.; \$5
<https://twincitiesroadsters.com/swap-meet>
- 11 **CMI** Membership meeting – **Ideal Hall, 1494 Dale St, St Paul**



Frequent Events:

Saturdays, Buffalo American Legion Cruise-In, Buffalo, (~~May 21, July 16, Oct 1~~) **11:00-4:00**

Saturdays, Anoka Car Show, corner of Fourth Avenue and Van Buren Street. **4-8 p.m.** (~~June 4, 11 and 25; July 16, 23 and 30; Aug. 6, 13 and 27; and Sept. 3~~) The season will wrap up with the **Sept. 17** finale.

3rd Tuesdays, Culvers Cruise Night, **Savage, 5:30 p.m.** 4725 Hwy 13

3rd Tuesdays, Montgomery Classic Car Roll-In, May-Sept; **4:00-7:00**

Wednesdays (every other), **Victoria** Classic Car Night (June 8- Sept 28) **5:00-8:00**

Wednesdays Weekly Wheels Car & Bike Meet, **Burnsville 5:00- 8:00** (May 18th – September 14th); Buck Hill, 15400 Buck Hill Rd

Wednesdays Cruise Night, **St. Paul Park, 4:00 – dark**; near railroad tracks on both sides of Broadway

Thursdays Classic Vehicles Roll-In @ The Little Market That Could, **Prior Lake 3:53-7:19** 16907 Hwy 13 S

Fridays, North St. Paul History Cruze, North St. Paul **6:00-10:00** Downtown, 7th Ave

*Do you have any shows/ cruises that you wish included?
Let us know at the membership meeting; or contact Jim Brandberg (jimbrandberg@aol.com)*

Check us out...



For more information on
Corvair Minnesota,
visit our website:
www.corvairminnesota.com

Follow us on
Facebook:
Corvair Minnesota



Public group · 249 members

(as of 08/29/2022)

Spot a Vair!



1961 Chevrolet Corvair Corphibian amphibious vehicle concept. Developed from a rear-engined Corvair Rampside pickup, it has a fiberglass hull and propellers driven hydraulically off the truck's engine. Throttle and rudder controls are located in the truck's cab and the bed.

*CMI is a non-profit corporation, chartered with the CORVAIR Society of America. Send CORVAIR Minnesota's \$20.00 annual dues, payable by Jan 01, to the CMI Treasurer. Membership in CORVAIR Minnesota entitles you to the monthly newsletter, the **Leeky Seel**, with free ads for members, a club window sticker, discounts on club activities, information on parts availability and good advice on the preservation and enjoyment of the CORVAIR automobile. **Yeah!***

THE LEEKY SEEL

408 7th St S
Hopkins, MN 55343-7722

TEMP – RETURN SERVICE REQUESTED



The September membership meeting will be held on the 13th at Ideal Hall – see you there!