

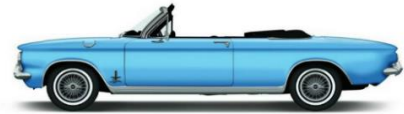

Leaky Seal

Corvair

January 2022



Corvair Minnesota Newsletter

President's message:

Merry Christmas everyone, and Happy New year, I hope Santa was good to each and every one of you!

Don't forget about your reservations for our Holiday party January 8th, contact Dave Pederson with your information for the party.

There will be no regular meeting in January, our Holiday party will be our meeting. Don't forget about paying for your dues.

Our next regular scheduled meeting will be Tuesday February 8th at Ideal Hall.

Don't forget to order your Corvair apparel, as car shows will be coming around in the spring, and we need to advertise our Club.

Birthdays in January:

Jerry Audorff
Cody Berge
Dan Quinn



Happy Birthday!

If you would like to add your name to the birthday list, please contact gailquinn263@msn.com

Thanks,
President Tom

Tom Quinn



Corvair Minnesota, Club Information Meeting Minutes

December 14, 2021

President Tom Quinn began the meeting at 7:04 pm.

Due to circumstances there was no tech session.Â

Some CMI members paid dues - if you haven't, you can pay Lee Knauf. Dues are \$20.

Chuck passed around a article of cars that are at the New Ulm museum.Â

GMCCA Dan Quinn - \$392.83 was received for each club. The reason the amount was so low, was because there we fewer cars and spectators. Hopefully next year GMCCA will be back up with the numbers. Help advertise for GMCCA.Â

Any questions regarding the Holiday Party, please contact Dave Pederson.Â

Financial Report:

End of November: \$4,347.71
Dues Collected: \$100.00
Current Total: \$4,447.71

16 people were in attendance. CMI would like to increase participation. We have 80+ members.

Bob Kaczke brought the Corvair apparel, along with a catalog that he

made of the different items that are for sale.

John Snyder won the pot of \$65.

Meeting was adjourned at 7:34 pm.

Amber Leah

CMI Secretary

OFFICERS

President

Tom Quinn
Tquinn1979@msn.com
(H) 651-489-2657
(C) 651-670-9224

Vice-President

Gary Nelson
corvaimelson@gmail.com
(C) 612-644-1258

Secretary

Amber Leah
amber.81.leah@gmail.com
(C) 612-251-9498

Treasurer

Lee Knauf
vairy69@comcast.net
(C) 952-448-6983

COORDINATORS

Technical Editor

Fran Schmit
schmfran@hotmail.com
(C) 952-929-9174

Club Wear Coordinator

Bob Kaczke
bkaczke@gmail.com
(C) 612-916-8769

SEEL Editor

John Herkenratt
jherken1@netzero.net
(H) 952-935-4596
(C) 612-719-4580

Member Coordinator

Jim Brandberg
jimbrandberg@aol.com
(C) 763-444-9334

BOARD OF DIRECTORS

1 year

Ron Scott
riskis@aol.com
612-600-0360

2 year

Dave Pedersen
dave14957@gmail.com
612-385-2241

Activities

Corey Cowden
Ratrodders@yahoo.com
763-226-4477



Library Lane

I'd like to remind everyone that there's no meeting on the 2nd Tuesday this month. The BOD decided that it was too close to the Holiday Party. I hope no one shows up and is disappointed. I don't know about you but I've been missing tacos for dinner before our meetings the last two months. I get to thinking about tacos all afternoon and it's hard to make the shift to a hamburger or soup. It doesn't quite bring me to tears or pitching a fit and I suppose I should be more flexible. Sharing the room with a tenor banjo and an emcee with a microphone last month didn't much do it for me either. Overall the Ideal Hall has been a good place for us for a year now. I have talked to a few people from the west side who absolutely won't make the trip but it used to be the same with people on the east side not wanting to go clear out to Wayzata. I think the BOD is open to suggestions but someone wanting a change of venue would have to do more than just come up with an idea, there's some work involved and they're doing enough already. Although we're just heading into the winter doldrums it is time to be thinking about events. Where do we want to go and what do we want to do in 2022?

I'm not sure what's going on with our Activities Director position but it would sure be nice to get someone in there. We've done some activities during the winter in the past but I'm not sure we've got anything in the works now. Covid doesn't help. We just need a place to get together and do something, anything.

Fran Schmit is the Technical Editor for the Leeky Seel these days but he's worn just about all the hats in CMI. We've had many a meal or picnic at the house on Library Lane in Saint Louis Park over the years. Mary's always had a knack for making us feel right at home, it's like being another one of the Schmit brothers or sons. I think they both grew up on the other side of St. Cloud and Fran majored in Physics at Saint John's and St. Cloud State, making use of the GI Bill. Fran's brother Joe helped get him in at Honeywell where he spent many years as a research scientist working on cool stuff like solar cells and fiberoptics. I always figured he worked downtown but it was more like St. Louis Park and Bloomington.

In the 60s some of the guys from work would go to the car dealerships on their lunch break when the new cars came out and Fran remembers being impressed by a brown Corvair convertible but he wasn't much for buying new cars, his first one being the current Buick. His first Corvair around 1970 was a blue '61 4-door with a Powerglide, purchased from a lady at work when she was transferred. He was quickly bitten by the Corvair bug and started dragging them home with a towbar for cheap. Sons Peter, Paul and Jim all got good at fixing them up and tearing them down for parts.

Fran's got an extra lot and the biggest garage in the neighborhood, they wouldn't let you build one that size these days. Fran's brother Chuck went to work for Boeing in Seattle and Lockheed in California and is another guy who's hip to the Corvair thing. Fran has an engineering mind and he's just naturally able to take things apart and figure out how they work. He's been a huge amount of help to me on many occasions when I get stuck on something, especially electrics. I get a little impatient sometimes when I just want to get the damn thing running and get out of the moment and he wants to start me out with Ohm's Law or something.

My impatience does not serve me well however since without a basic understanding I often can't remember how I got out of trouble the last time. I gotta get over there and learn some more things like putting Late differential parts in an Early case. Covid doesn't help. I don't know if anyone's done more for CMI than the Schmit's and I'm very glad to know them.

Jim Brandberg

Fran Learns Yet-Another Lesson!

Fran put a Latching Relay on the Automatically Primed Fuel Pump of his FC. Now he attempts to duplicate that effort on his '66. An older Modification comes up and bites him! Follow... See the Latching Relay and

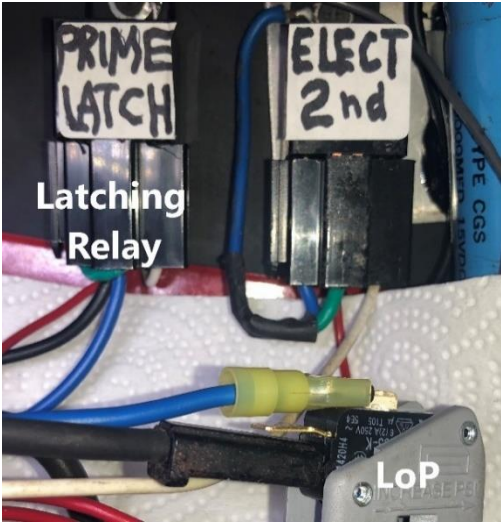

LowPressure switch, (LoP): mounted on the '66 engine, in the figure on left. Relay's wires are Red, Blk and Blu. GRN and WHT wire (GND) not seen. RED wire is from the Key. BLK wire goes to the LoP (and is shown attached to the LoP Switch). BLU wire comes from the Strtr terminal to Latch the relay. GRN wire attaches the NO Relay Terminal to the Relay's Coil. Coil is grounded to car frame. A different BLU wire (shown with Yellow insulator, on LoP), goes from the LoP up to the LED at the dash of the '66 to power the LED and through a diode, powers the FP's relay. (Relay and in-tank FP are up front)

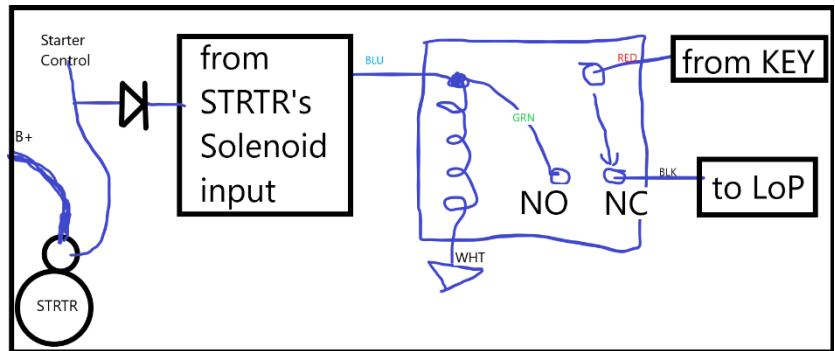

The wire from the STARTER Relay (the Original big Purple wire) is tapped at its original connector, near the Umbilical. Note lack of the Yellow wire. This tap provides the control signal for the Latching Relay.

Here's a sketch of the setup on the '66.

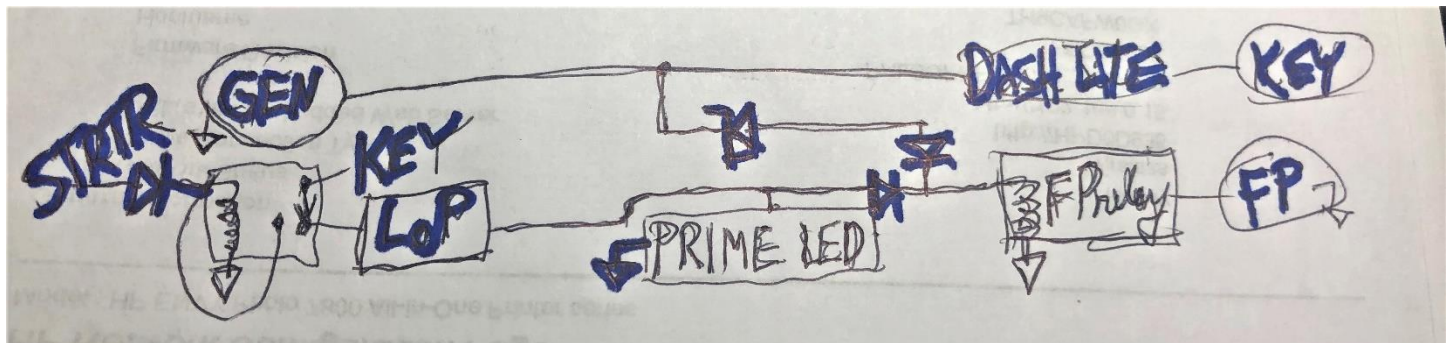

HA! The '66 has the Special engine, (180 psi on cranking) which required a BIGger starter motor, [Clark's Gear Reduction Starter Motor] which doesn't come with a yellow wire (the resistor bypass) so when the KEY input got latched over to the NO contact it Latched the Relay but also sent a signal back up that wire and kept the Starter Motor engaged! So, a diode had to be added into that control circuit. You can see in the drawings above, they went back into the sketches, and added that diode.

Live and Learn, while we always have FUN, as we keep on CORVAIRing! Fran



Corvair Minnesota Holiday Party

**Saturday, January 8th, 2021
TST Creative Catering/ Ideal Hall
1494 Dale Street N, St Paul**

**Social Hour: 4:00 pm – 5:00 pm
Cash Bar is available**

**Dinner is served at 5:00 pm
* * *Reminder only * * ***

Dinner options:

**Stuffed Chicken Breast
(with Wild Rice & Sausage)
Garlic Mashed Potatoes
Carrots**

**Roast Beef
Mashed Potatoes
Carrots**

**Vegetarian Ravioli
Vegetable Medley**



All will be served with:

Salad w/ Dressings, Rolls & Butter, and Chocolate Caramel Cake

Questions/directions: call Dave Pedersen @ (612) 385-2241

**** \$20.00 dues for 2022 are payable at the Party or mail check to: ****

**Lee Knauf
401 West Street
New Ulm, MN 55073-1527**



Corvaair Preservation Foundation and the Corvaair Museum



The Corvaair Preservation Foundation (CPF) - an affiliate of the Corvaair Society of America - is a 501(c)(3) non-profit corporation which is dedicated to preserving and promoting the history of the Corvaair. The mission of the Corvaair Preservation Foundation is to document all aspects of Corvaair history and to preserve significant Corvaair artifacts for the enjoyment and education of the public.

Corvaair Museum. The CPF operates the [Corvaair Museum](#) where you will find a surprising number of pristine Corvaair cars, trucks, powertrain displays and other memorabilia. The address is 10041 Palm Road - a.k.a. Route 66 - in Glenarm, Illinois. Property and income for the museum are obtained solely from donations from individuals and organizations alike. To become a Corvaair Museum Member, [click HERE](#). To make a tax deductible donation to the Corvaair Preservation Foundation, [click HERE](#). Your support is greatly appreciated!



Visit the Corvaair Museum!

We're located at 10041 Palm Road - a.k.a. Route 66 - in Glenarm, Illinois, just a few short miles south of Springfield. It's in close proximity to popular tourist destinations in the Springfield area. Attractions include the Abraham Lincoln Presidential Library and Museum, Lincoln Home National Historic Site, Lincoln's Tomb and War Memorial State Historic and more – all just minutes away.

The Springfield area is served by Allegiant, American and United Airlines with multiple daily flights connecting to Chicago, Dallas / Fort Worth, and Punta Gorda Airport.

The museum's location also has the benefit of being easily accessible from Interstate 55 - the main corridor between Chicago, St. Louis and New Orleans.

A Diode

is a device with two contacts, from the Greek word for two, which is evidently spelled Di! A solid state diode is shown on the right compared to an ordinary finger tip. This is a common version but there are larger ones in Power Plants and smaller one in computer chips, but this is one a person can put into their car if they need one! A Diode allows current to flow in only one direction while , at the same time, it can allow another current to go through, the other way! A lot like a traffic cop who can wave an Eastbound car through but stop a west bound one.

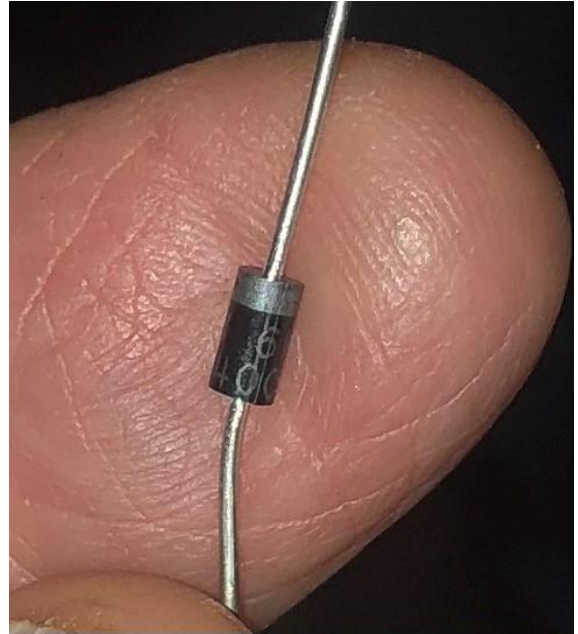

The photo shows a modern Solid State version with a white band on one end. The band points as if it were an arrow – showing which way the current flows, from Positive to Negative. You'll find out pretty quickly if you put it in backwards.

A recent example came up where the addition of such a diode helped out in the design of a circuit used in a CORVAIR. The Automatic PRIME circuit was turning on the HeadLight (HL) circuit during the priming function. It doesn't hurt anything, just looks dumb to flash your lights, so the diode went in.

A DIODE isa handy gadget to know about. If you are not familiar with them ask around, as there are folks who can tell you.

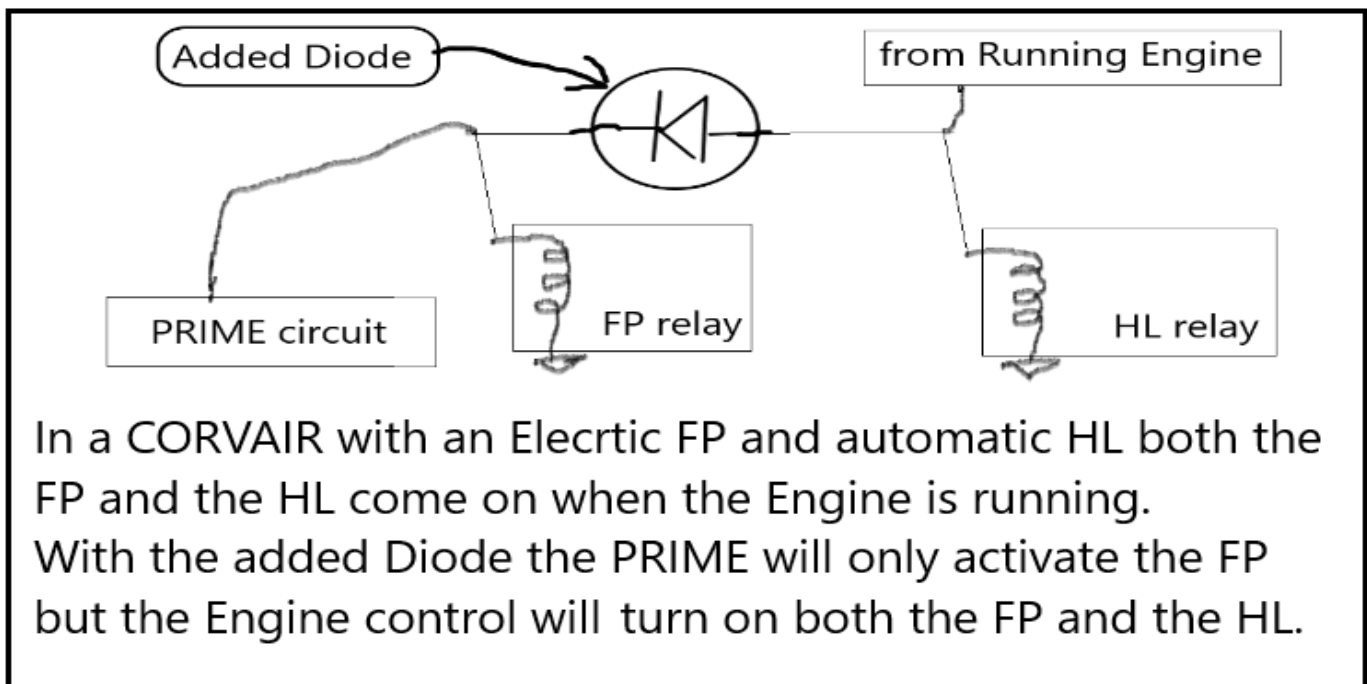

Just ask Fran, he'll tell you - while you KEEP ON CORVAIRING!!!

[2022 CORSA International Convention \(2022corsaconvention.com\)](http://2022corsaconvention.com)

2022 CORSA CONVENTION



DAILY SCHEDULED ITEMS

- Registration - Tuesday through Friday - 8:00 AM to 5:00 PM - Lobby Room 128
- Hospitality - Tuesday through Friday - 8:00 AM to 6:00 PM - Lakeside
- Vendor Sales - Tuesday through Thursday - 8:00 AM to 6:00 PM - McIntosh
- Swap Meet - Tuesday through Thursday - 8:00 AM to 6:00 PM - Parking Lot

CONVENTION SCHEDULE - JULY 12 TO JULY 16, 2022

Host hotel and reservations: [Host Hotel \(2022corsaconvention.com\)](http://Host Hotel (2022corsaconvention.com))

CMI Classifieds



Raffle Tickets

Order your tickets (\$10.00 each) and see photos of the car here:

[Corvair Raffle Tickets](#)



Here's a pair of metal moldings- I think they might be for an Early Sedan, maybe, but they look like something a person would want: If anyone wants them, ask me. Fran

For Sale? Wanted? Lost/ Found? What have you got?

For Sale
1960, 1961, 1962 & 1963 New and Very Good Rocker Panel Trim (3 sets)

Also:

- 1960-69 rebuilt starter, includes drive & housing
- Two early FC headlight bezels, very good condition. \$50 each
- Relined late front brake shoes \$30

Contact Jerry Berge at 480-250-8816 June 2021

Leeky Seel Classified ads
Do you have a Corvair related item you would like to sell or are in search of? Send your request for an ad in the **Leeky Seel** to: corvairmleekyseel@hotmail.com.
Deadline is the 25th of the preceding month.

Check us out...

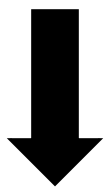

For more information on
Corvair Minnesota,
visit our website:
www.corvairminnesota.com

Follow us on
Facebook:
Corvair Minnesota



Public group · 184 members

(as of 01/01/2022)

Spot a Vair!



HAPPY NEW YEAR

*CMI is a non-profit corporation, chartered with the CORVAIR Society of America. Send CORVAIR Minnesota's \$20.00 annual dues, payable by Jan 01, to the CMI Treasurer. Membership in CORVAIR Minnesota entitles you to the monthly newsletter, the **Leeky Seel**, with free ads for members, a club window sticker, discounts on club activities, information on parts availability and good advice on the preservation and enjoyment of the CORVAIR automobile. **Yeah!***

THE LEEKY SEEL

408 7th St S
Hopkins, MN 55343-7722

TEMP – RETURN SERVICE REQUESTED



*There will be no January membership meeting
– see you at the Holiday party on the 8th.*