

# LEEKY



# SEEL

CORVAIR MINNESOTA NEWSLETTER

## CMI Schedule

## June 2017

Membership meetings are on the 2<sup>nd</sup> Tuesday of each month at 7 p.m. (unless otherwise announced)

Boards of Directors' meetings are on the last Thursday of each month (unless otherwise announced)

- June**
- 04 GMCCA – State Fairgrounds**
  - 11 Buffalo Days Car and Air Show (<https://buffalochamber.org/buffalo-days/>) (set up 12-1pm)
  - 13 Membership meeting – Wagner's Drive In**
  - 23-25 Back to the 50's, State Fairgrounds ( [www.msra.com](http://www.msra.com) )
  - 27- July 01 CORSA convention, Independence, MO**
  - 29 Directors' meeting
- July**
- 04 Fourth of July Parade, Delano – Post Parade Picnic @ the park**
  - 06-08 Iola Old Car Show and Swap Meet (Featuring Camaro)
  - 11 Membership meeting – Minnetonka Drive In**
  - 27 Directors' meeting
  - 28 North St. Paul Weekly Car Show**
  - 28-30 Little Log House show, Hastings (<http://www.littleloghouseshow.com> )
  - 28-30 Kolacky Days, Montgomery, MN (Classic car show 7/29; 9 am-3 pm)  
(<http://www.montgomerymn.org/thursday-july-25/> )
  - 30 10,000 Lakes Concours d' Elegance, Excelsior (<http://10000lakesconcours.com/> )
- August**
- 08 Membership meeting – tbd – looking for membership input**
  - 12 New London – New Brighton Antique Auto Run (<http://www.anticquecarrun.org/> )
  - 20 Pantowners Car Show, Benton County Fairgrounds  
(<http://www.pantowners.org/carshow.html> )
  - 24 Director's meeting
  - 26 Summer Spectacular 9 am - 3 pm; Farmington (<http://thesummerspectacular.com/> )
- September**
- 12 Membership meeting - MUM**
  - 14 (Thursday) New Ulm Car Hop & Shop 5-8 p.m.
  - 09 Classics by the Lake Car Show, Buffalo, MN 10 am – 2 pm (*be there by 8 for a good spot*)
  - 17 Christ's Cross Car and Craft Show, Ham Lake, MN (<http://www.christscrosscarclub.org> )
  - 28 Directors' meeting

# CORVAIR MINNESOTA

May 09, 2017

President Jack Bacon called the meeting to order promptly at 7:00 at the MUM. 19 members were in attendance including Larry LaBathe from Chisago City who was attending his first meeting. Larry has a '63 convertible which he is bringing to GMCCA. Grandson Cody accompanied Jerry Berge so they joined the usual father/son teams of Fran and Peter Schmit and Tom and David Quinn, good to see!

Following the creed, we went around the table reminding everyone of our names, what we own, and is it ready for GMCCA.

## Treasurer's Report:

April 10 balance	\$2687
Income	\$126
Expenses	<u>(\$134)</u>
Current Balance	<u>\$2679</u>

Motion to approve by Ray Alexander, seconded by Rich Buratto, motion carried.

**Secretary's Report:** Minutes were read. Motion by Jerry Berge to approve, seconded by Tom Quinn, motion carried.

## OLD BUSINESS:

**Floor Pan Fixture:** Jim Brandberg had taken possession since no one wanted it and it was too good to scrap. Clark's has called and now is interested in it!

## NEW BUSINESS:

### Upcoming Activities:

**This coming Saturday, May 13: Adopt-a-Highway.** Meet at 8 a.m. for breakfast at Dobo's on Hwy 55.

**May 20:** AAH backup date.

**June 4, 2017:** GMCCA Car Show & Swap Meet at the MN State Fairgrounds. **SPREAD THE WORD!** Bring your registration to any CMI event to **save postage.**

**June 11: Buffalo Days Car and Air Show:** Unique and entertaining event held at the Buffalo Airport featuring an actual air show.

**June 13, 2017:** CMI Membership Meeting at Wagner's Drive-In.

**June 14:** First **Victoria Car Show** of the season. Excellent West side event held every other week throughout the summer.

**June 23-25, 2017:** MSRA "Back to the 50's" Car Show & Swap Meet at the MN State Fairgrounds. **All Earlies** should enroll and park in a group. Plans are in process for all earlies to attend as a group.

**June 25: Auto Fest Car Show in New Ulm:** Good show in the Southwest!

**June 27 – 30, 2017: Corsa National Convention** in Independence MO—1 month to complete your corvaire projects!

**July 4, 2017:** Once again, we are considering the Delano parade; last year's participation was a tad light so we need to assess the level of interest before committing.

**July 11, 2017:** CMI Membership Meeting at Minnetonka Drive-in.

**July 28: North St. Paul Weekly Car Show:** Featured marque parking is down the street this year, Neat event on the East side!

**August 8, 2017:** CMI Membership Meeting—location Suggestions?? **Anxious for ideas of drive-ins or restaurants with BIG parking lots. What side of the Metro haven't we covered?**

**Winter:** Bill Bertram volunteered to host the Holiday Dues Party, details to follow.

**Summer 2018: American Legion National Convention, Minneapolis, MN.** Fran was contacted and we may have an opportunity to be featured in their parade once again. Joe Schwert volunteered to coordinate cars and drivers. Let Joe know if you have a convertible available AND/OR if you are willing to drive someone else's excess convertible. Also, Rampsides may be used.

Meeting notes, Continued to page 4

View under a Late Right Rear wheel.

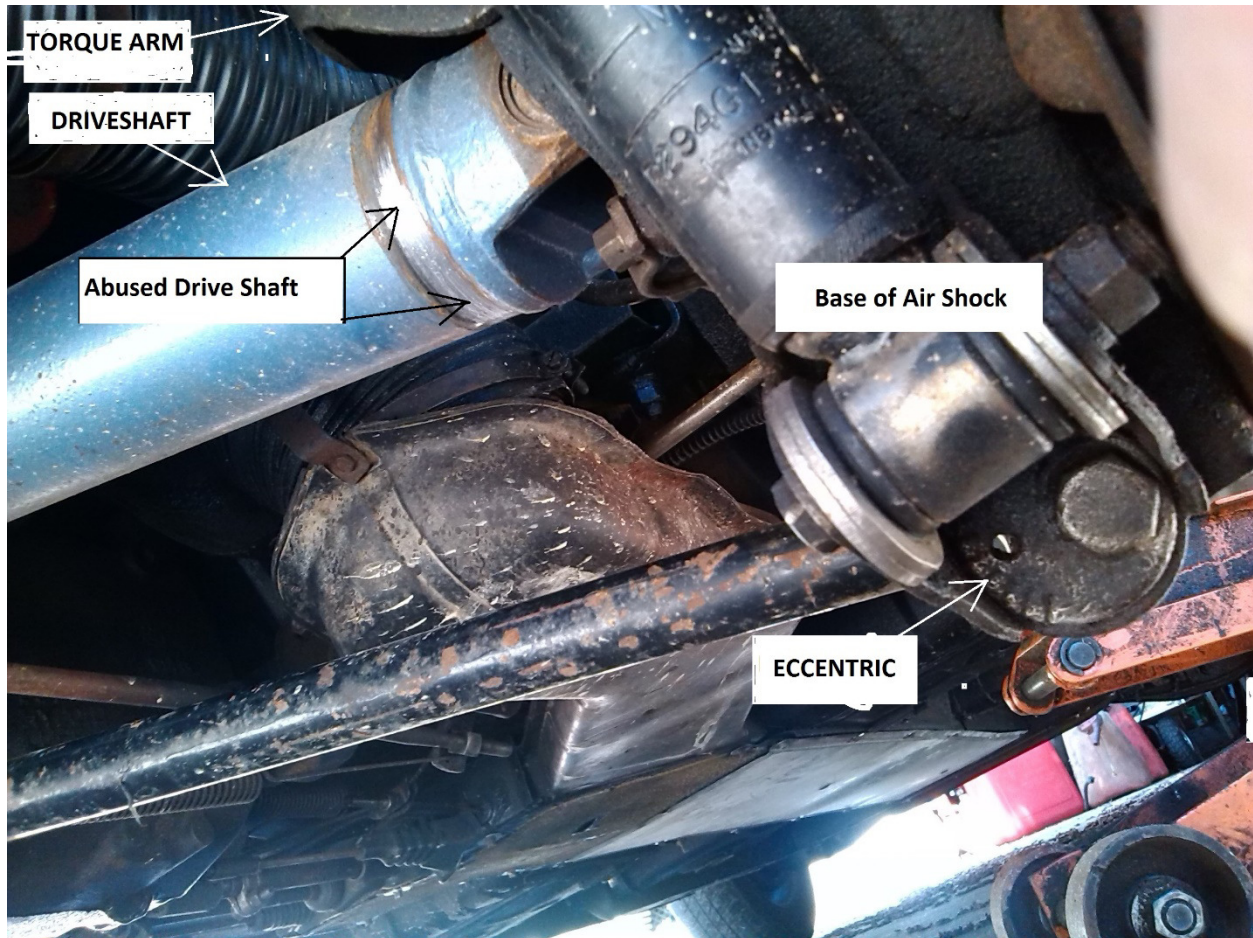

If you are working on your Late Model's suspension and forget to tighten the nut on your  
"Eccentric Camber Adjuster"

it could turn – all by itself – to a position it likes better than where you put it.

You might say, "so what?" To which I might reply, "take a look!"

When that Eccentric rotated to a lower energy state – all the way out – it let the Torque Arm  
With the wheel and axle go way out (on the bottom) meaning maximum CAMBER.

Turns out that MAXIMUM means "as far as it can go!" It cannot go any further because the U-  
joint is cranked over so far that the driveshaft is rubbing up against the Torque arm and, since  
that shaft is actually only a thin hollow tube, could be cut off if you drove much further!

It is interesting to see how far out that wheel can come with the adjuster completely OUT. I  
would guess I could have cornered, really well! Turning left, anyway.

Happy CORVAIRing,

*Fran*

*Meeting notes, Continued from page 2*

**Summer 2018: Corsa National Convention, Pittsburgh, PA, 13 months.**

**Summer 2019: Corsa National Convention, St. Charles, IL, 25 months.**

**Summer 2020: Corsa National Convention, San Diego, CA, 37 months, 1978 miles.**

**Other Discussions:** A desire was expressed for more driving events, ala Econo-Run and Rallies. There is an interest, any leaders??

Tim McNiff's "Welcome Home" ad featuring a late Corvair convertible!

Original Parts Group (OPGI.com) is adding Corvairs!

New Ulm Car shows will be held the **second Thursday** of each month.

**Treats:** President Jack stopped on the way to the meeting, excellent improv!

#### **Technical Session:**

Once again Jim Becker provided education on the electrical system. Tonight we covered alternators (both 37 & 47 amp) and voltage regulators. Further, he explained the circuitry of the so-called idiot lights and demonstrated that they are actually cleverly designed, a perspective I had never had explained to me before. Nevertheless, I'm glad we did not have a pop quiz to draw the circuit at the conclusion!

#### **Future Technical Session:**

Reminder: CMI's goal is to help members get more cars on the road and drive them more often. What help or advice would you like? Let JIM BECKER know what projects YOU want to know more about or even help performing. Operations can be performed during our regular meetings or we can have off-site gatherings at your house or a parking lot.

The more Corvairs on the road, the more fun we can have!

Meeting adjourned at 8:45.

Respectfully submitted,

*Chuck Johnson*



35th Annual General Motors Car Clubs Association

# ALL GM CAR / TRUCK SHOW AND SWAP MEET



Live DJ playing music  
Food vendors on site!  
Dash plaques to first 500 show vehicles!

**SUNDAY, JUNE 4, 2017 • 8 AM - 2 PM**  
**MINNESOTA STATE FAIRGROUNDS - MACHINERY HILL**

### SPECTATORS

\*General Admission: \$5.00/Adult  
\*Children under 12: FREE

### EVENT INFORMATION

[www.gmcca.com](http://www.gmcca.com)  
[www.facebook.com/GMCCAssociation](http://www.facebook.com/GMCCAssociation)

**\*STATE FAIR RULES PROHIBIT:  
OPEN FIRES, BBQ'S AND  
ALCOHOLIC BEVERAGES.  
PETS ON LEASHES ONLY**

### PARTICIPANT AWARDS FOR

**BUICK • CADILLAC • CHEVROLET • CORVAIR • CORVETTE • CAMARO • CHEVELLE • NOVA  
OLDSMOBILE • PONTIAC • SATURN /OTHER GM • CHEVROLET/GMC TRUCKS**

**Show Vehicles:** Gates open at 7am - Enter at intersection of Larpenteur Ave & Underwood.

**For Sale Vehicles:** Gates open at 7am - Enter at intersection of Larpenteur Ave & Underwood.

Pre-register for guaranteed space (until 10AM) & reduced entry fee.

**Swappers:** Gates open at 6am - Enter at Snelling Avenue Main Gate - All Makes of auto parts are welcome!

**Spectators:** Gates open at 7am to the show/swap area.

Please print legibly or use address label

### **REGISTRATION FORM**

Name \_\_\_\_\_

Street \_\_\_\_\_

City \_\_\_\_\_ State \_\_\_\_\_ Zip \_\_\_\_\_

Phone (    ) \_\_\_\_\_

Car Club Affiliations (if any) \_\_\_\_\_

### GM SHOW VEHICLE

Make \_\_\_\_\_ Year \_\_\_\_\_

Model \_\_\_\_\_

Preregister before May 15th - \$10 per vehicle

Register after May 15th - \$15 per vehicle

Includes Car, driver & one passenger per admission.

### SWAP SPACE - 15'x 20' Space

\$10 each preregistered before 5/15

\$15 each after 5/15

### FOR SALE AREA VEHICLES (All Makes)

\$15 per vehicle preregistered before 5/15

\$20 per vehicle after 5/15

**NO 'For Sale' signs allowed in the show area**

**Make checks payable to and send  
pre-registration form to: GMCCA  
9632 Wyoming Terrace  
Bloomington, MN 55438**

# Corvair Society of America International Convention

June 27-July 1, 2017

# The Vairs Stop



## Independence, MO

Home of Harry Truman and the Truman Library

The Heart of America Corvair Owners Association welcomes the members of CORSA to Independence, MO (a suburb of Kansas City) for its 46th annual convention. The goal of HACOA is to make your trip to the convention easy and fun, your stay a joy, your return safe, and your head full of fond memories of the 2017 CORSA International Convention.

- Host Hotel: Hilton Garden Inn, Independence, MO
- Tentative Schedule Updated 5/23/17
- Registration Form (PDF Download) Updated 3/13/17
- Online Registration Updated 3/13/17  
*You must be a CORSA member to register, and you must be logged in to your CORSA member account to register online.*
- Preparing your Corvair for the trip (PDF Download)
- First Timers
- Welcome Party
- Valve Cover Race
- Tours Updated 2/26/17
- Area Attractions
- Concours d'Elegance
- Tech Sessions
- Meetings
- Economy Run
- Rally
- Autocross
- Banquet Menus
- People's Choice Car Display
- Convention Survey

<https://www.corvair.org/2017convention/>

# GAS TANK TALK

The other day I was working on my gas tank. The float had a leak so I had to R&R it and do a quick solder job.

Here's how the outside part of a gas tank pickup-port appears, when it is away from the tank. I'm showing you four things. The largest is the sealing plate that covers the hole in the tank and allows us access – it's the structure that holds all of this together. The wire going off into the distance is also an important part of the discussion. The pipe carrying the fuel is also part of the story. #4 is the other wire shown in the photo: the ground connection...the important part of the story I am about to tell. Turns out that it is welded onto the access plate and as such when you are bending and moving this whole unit around - - you can snap off that welded connection. Or, as I did, snapped it off after I had reinstalled the unit and it was all snugly into the hole – ready to go into operation!



Well - - SCHMIT! What are we going to do about that? It has to be there because that wire going off into nowhere at the top of the picture is the one up to the gas gauge...and this ground wire is the other end of that circuit.

The wire from the dash comes down to this access plate. The wire allows current to pass through the sensor in the tank. That sensor is welded onto the pipe that is used to remove the gas from the tank, passing along the sensor-current ...and that pipe is soldered into the access plate which has our ground wire welded onto it. Let's draw this out a little bit. Follow the dashed line!

I've drawn those words that show the current flow from the dash unit into the tank and through the sensor, then up the pipe and out to the ground. That is what you must have.

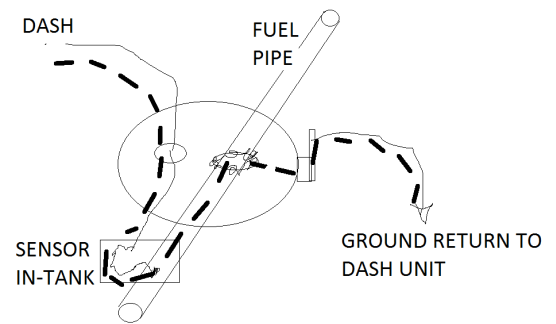

When I snapped off that ground wire my system was dead - unless I took the unit out of the tank and re-attached the ground wire to the access plate, where it had been. I didn't want to take it out again, so I thought about it for a while.



Here's what I used to solve my dilemma.

A hose clamp!

It's a metal clamp that can be connected to a wire (for conducting electric current) and the metal 'current-conducting' hose clamp can be slipped around the Fuel Pipe shown in the above diagram/photo - - and secured with a screw driver...right?

Problem was the clamp is stainless and I can't solder to stainless so I tinned the ground wire (nice and fat) and opened the screw slots at the end of the clamp so the big fat leaded wire would go through. Then I smashed the end of the clamp together capturing the fat wire in the stainless teeth. I screwed all of this (completing the circuit) to the steel pipe coming out of the tank without having to fight with that soft insulating o-ring under the access plate.

Fran

# CMI Classifieds

**New:** Engine electrical harness, ball joints, Pertronix ignition; headers (110 and 140); custom exhaust; Wallen rebuilt starters generators and alternators; mufflers; rebuilt flywheels; new belly pan for late; crank and rod bearings.

**Used parts:** complete engines, transmissions, differentials: call for parts – I have a large inventory.

**Also:** 1969 110hp engine (runs great, sealed & pretty) Rare – aftermarket tube style early air grill – Solid flywheel

*I also offer full time Corvair repair*

Gary Nelson 612-644-1258

\*\*\*\*\*

**1965 CORSA** 4sp, 2dr <SHOW QUALITY – ed.>  
Complete Restoration, factory A/C ('66 style),  
Black/black \$18,000 Hill Sweet 952-926-7803



\*\*\*\*\*

**1967 Monza** coupe, family owned for almost 50 years. Stored inside all seasons and I do not drive it on wet roads or chemically treated roads. The odometer says about 117,000. New carpet and seat covers and repainted. Documentation from original purchase to current. Asking \$12,000. Greg Helm [helmster@integra.net](mailto:helmster@integra.net) or my home phone 952-447-6495 Savage



\*\*\*\*\*

Corvair Owner's Manuals: 1965, 1967 (2), 1968 (2)  
Corvair Shop Manuals: 1960, 1962 plus Supplement,  
1965, 1966, 1968  
Corvair P&A Catalog: 1960-1969 (one manual)

it's been a while since I physically checked on them but last I did, that's what was there. If someone has interest, I'll verify I still have them. All are originals - no repros. They've been stored in boxes and file cabinets over the years, so they're in really good condition. Ron

If interested, contact Chuck Johnson by email ([cljohnson99@gmail.com](mailto:cljohnson99@gmail.com)) or at our Monthly meeting.

\*\*\*\*\*

**For Parts:** 3 lates, 2 coupes and 1 convert. Probably too much rust to restore, but they may have the part you need. Contact Rich Storlie [storlieaircooled@yahoo.com](mailto:storlieaircooled@yahoo.com)

\*\*\*\*\*

**1965 Monza** 110 4 door automatic. Blue Bucket seats. About 55 thousand miles. We (dad) are second owner. Bought for elderly lady around 1975. Ran when it was last parked around 10 years ago. Needs brake work now as peddle goes to floor. All original with very little rust. Would not take much to get it road worthy. Asking \$1900 or BO. 651-436-5565 Rick

\*\*\*\*\*

**1965 Monza** My father in law said it has 76,000 miles on it but he is not sure if it had rolled over or not. 140 horsepower, with two mufflers. It has a four speed manual transmission. As you can see it is red with the red interior, two door convertible. It does have a radio with a cassette deck. My father in law would like to start at \$11,000. Our contact information is Neil or Patty Herzberg, 320-243-3085 and it is okay to leave a message. We live in Paynesville, MN.





# CMI Classifieds- cont.

## 1964 Corvair Convertible

2nd owner, 43K miles, four speed, 110HP Exterior: Maroon, Interior: Black, no rips/tears. Top & rear window in excellent condition. Dual exhaust, spinner hub caps. \$8,900. Curt Robinson 952 934-6069 or [Curtnanrob@aol.com](mailto:Curtnanrob@aol.com)



\*\*\*\*\*

**1963 Monza** 110 Engine 4 speed, was running when put in storage, we have title, need to have key made. The car is located in Rogers, MN. \$2,000 obo. Ron Lucas 763-242-4090; 763-226-8440; 763-420-2569 [lorrynelucas7@gmail.com](mailto:lorrynelucas7@gmail.com)



\*\*\*\*\*

**1962 Monza Coupe**- Slightly over 42,000 miles, runs well, no rust, in very good condition. Automatic transmission, four new tires. White with black interior. Fun to drive but at my age it's getting tougher to get in and out! Make offer Bill Von Hassel 952-946-2245 or [VonH9700@aol.com](mailto:VonH9700@aol.com)



**1964 Monza Spyder.** Turbo/ 4 speed with 49,000 original miles. The car is mint! Call with questions or to see the car. Burt Rovner 763-286-2075 [burt.rovner@gmail.com](mailto:burt.rovner@gmail.com) (note: This is Clarence Jansson's car)



\*\*\*\*\*

**WANTED:** Beg/borrow/steal early 4 bolt wheels with tires that hold air. I will be helping a fellow extricate a '64 coupe from long term poor storage and anticipate needing tires which hold air! Chuck Johnson. 952.240.0414 [cjohnson99@gmail.com](mailto:cjohnson99@gmail.com)

\*\*\*\*\*

**Help Wanted:** I previously owned a 1966 Corvair Coupe that was dark blue. I believe I sold it to a person that was interested in preserving the car in 1980. Any ideas about how to run this car down would be appreciated. I bought the car new. It was in excellent condition when I sold it. Thanks much! Spence Angel 29144 Golf lane Lindstrom, MN, 55045 [spencerang@aol.com](mailto:spencerang@aol.com) 612 309 5994 cell

**WEBSITE:** <http://www.corvairminnesota.com/>

**OFFICERS:**

**PRESIDENT**

Jack Bacon  
195 Mallard Lane  
Loretto, MN 55357-9523  
763.479.6214  
jackchrisbacon@hotmail.com

**TREASURER**

Lee Knauf  
401 West Street  
New Ulm, MN 56073-1527  
952.448.6983  
vairy69@comcast.net

**VICE-PRESIDENT**

Jim Becker  
12930 37th ST  
Clear Lake, MN 55319-1101  
320-743-2889  
mr.jebecker@gmail.com

**SECRETARY**

Chuck Johnson  
9632 Wyoming Terrace  
Bloomington, MN 55438-1640  
952.240-0414  
cljohnson99@gmail.com

**MEMBER COORDINATOR**

Jack Bacon  
195 Mallard Lane  
Loretto, MN 55357-9523  
763.479.6214  
jackchrisbacon@hotmail.com

**COORDINATORS:**

**TECHNICAL EDITOR**

Fran Schmit  
3370 Library Lane  
St. Louis Park, MN  
55426-4224  
952.929.9174  
schmfran@hotmail.com

**CLUB WEAR**

Bill Cook  
600 10<sup>th</sup> St S  
Buffalo, MN 55313-5025  
612.940-9179  
wdcacook@yahoo.com

**HISTORIAN**

Cara Knauf  
401 West Street  
New Ulm, MN 56073-1527  
952.448.6983

**EDITOR**

John Herkenratt  
408 7th St S  
Hopkins, MN 55343-7722  
Jherken1@netzero.net

**HAPPY  
FATHER'S  
Day!**



.....

**CMI is a non-profit corporation, chartered with The CORVAIR Society of America. Send CORVAIR Minnesota's \$20.00 annual dues, payable by Jan 01, to the CMI Treasurer. Membership in CORVAIR Minnesota entitles you to the monthly newsletter, "The Leeky Seal", with free ads for members, a club window sticker, discounts on club activities, information on parts availability, and good advice on the preservation and enjoyment of the CORVAIR automobile.... Yeah!**

**THE LEEKY SEEL**

3370 Library Lane  
St. Louis Park, MN 55426-4224  
**TEMP - RETURN SERVICE REQUESTED**



*Busy Summer Season ahead-*  
hope to see all your cars out there!