

LEEKY



SEEL

CORVAIR MINNESOTA NEWSLETTER

President's Page

April 2017

Greetings from sunny Key Largo, Florida! Chris and I spent the last ten days in Key Largo soaking up sunshine and exploring the local attractions in the Florida keys. I was surprised to find there was a Home Depot in Key West and also in Marathon.

I went to my first car show of the year in Marathon with about 24 cars. My favorites were a 49 Chevy Pickup and a 1960 Bugeye Sprite. I spotted quite a few daily driver classic cars throughout the keys My favorite was a VW transporter parked in front of Lucy's Retired Surfers Bar and Restaurant in old Key West. The food and wait staff was great!

Spring is finally here and it's time to get your cars out of hibernation. Please join us at the MUM April 11 at 7 pm for our membership meeting along with a great tech session. Then Saturday April 29 at 9 am is our spring kickoff breakfast at Park Tavern in St. Louis Park. Everyone drive their Corvairs and we will do some tire kicking in the parking lot.

The CORSA convention June 27 - July 1 now has online registration open www.corvair.org.

Wrench, Drive, Repeat!

Jack Bacon



Corvair Society of America International Convention

June 27-July 1, 2017

The Vairs Stop



Here



Independence, MO

Home of Harry Truman and the Truman Library

CORVAIR MINNESOTA

March 14, 2017

President Jack Bacon called the meeting to order at 7:08 in the lobby of the Minneapolis/St. Paul International Auto Show. 19 members were in attendance, and two guests: Loren with Ralph Diers and Scott with Joe Schwert.

Treasurer's Report:

January balance	\$2621
Income	\$205
Expenses	<u>(\$90)</u>
Current Balance:	<u>\$2736</u>

Motion to approve by Fran, Tom seconded, motion carried.

Secretary's Report: Motion by Jack, seconded by Fran to Approve without reading.

OLD BUSINESS:

February 24: JR Plating, North Branch

Seven members toured this facility where nickel and chrome plating are skillfully performed, even 3-D parts! The staff has over 100 years of experience and does beautiful work.

NEW BUSINESS:

Check out the Corvair MN website! Reminder to take a few minutes to appreciate the work one of our members invests in our club.

Upcoming Activities:

April 11, 2017: Membership meeting at the MUM. . .maybe drive a Corvair! TECH SESSION will be on building Valve Cover Racers!

April 29: Pancake breakfast at Park Tavern in St. Louis Park at 9 a.m. We will be in the room to the right as you come through the front door. An informal spring vehicle check-up will occur in the parking lot across the street, weather permitting.

May 9, 2017: Membership meeting at the MUM.

June 4, 2017: GMCCA Car Show & Swap Meet at the MN State Fairgrounds. SPREAD THE WORD! Bring your registration to any CMI event to **save postage.**

June 13, 2017: CMI Membership Meeting

June 23-25, 2017: MSRA "Back to the 50's" Car Show & Swap Meet at the MN State Fairgrounds. All Earlies should enroll and park in a group.

June 27 – 30, 2017: Corsa National Convention in Independence MO—3 months to complete your corvair projects!

July 4, 2017: Once again, we are considering the Delano parade, last year's participation was a tad light so we need to assess the level of interest before committing.

July ??: North St. Paul Weekly Car Show: Tom Quinn is confirming a date for our club.

Winter: Bill Bertram volunteered to host the Holiday Dues Party, details to follow.

Summer 2018: American Legion National Convention, Minneapolis, MN. Fran was contacted and we may have an opportunity to be featured in their parade once again. Joe Schwert volunteered to coordinate cars and drivers. Let Joe know if you have a convertible available AND/OR if you are willing to drive someone else's excess convertible. Also, Rampsides may be used.

Summer 2018: Corsa National Convention, Pittsburgh, PA, 15 months.

Summer 2019: Corsa National Convention, St. Charles, IL, 27 months.

Summer 2020: Corsa National Convention, San Diego, CA, 39 months, 1978 miles.

Technical Session:

Out of the box: Touring the Auto show was our technical session! Everyone enjoyed the new vehicle displays as well as the 10,000 Lakes Concourse display of Antique and Classic autos. The 10,000 Lakes is July 30th this year so it is not in conflict with GMCCA for once!

Meeting notes, Continued to page 3

Meeting notes, Continued from page 2

We are getting our cars out, so:

Future Technical Session: Fran, Jim(s), and Gary, along with many others, have a wealth of Corvair knowledge and experience. Let JIM BECKER know what projects YOU want to know more about or even help performing. Operations can be performed during our regular meetings or we can have off-site gatherings at your house or a parking lot. What needs to be upgraded or fixed on your Corvair in order for you to drive it more this summer? The more Corvairs on the road, the more fun we can have!

Meeting adjourned at 7:30.

Respectfully submitted,

Chuck Johnson
CMI Secretary



Late Model Speedo Cable HELP

There is a problem with the LM speedo cables that can be almost completely avoided by taking the kink out of the cable position. The factory puts a clamp on the cable right where it passes the brake hose mount. The cable is actually tied down to the brake hose mount, which is too tight when you make a full left hand turn. Of course, if you only drive straight ahead you will not encounter this problem. To reduce your chance of a failure all you need do is release the cable clamp so the speedo cable hangs freely between the brake hose mount and the upper A-arm of the front suspension. Work the wheel back and forth (left to right) and you will see where it likes to float. Get a tube of Silicone rubber and put a big gob around the cable to hold it up against the brake hose, a couple inches from the factory location. When the silicone is set up, in a day or two, swing the wheels around some more and you will see that another gob might be in order. This second application keeps the cable behind the a-arm instead of on top of it. Just pump some rubber on the cable and let it cure against the back of the A-arm. Once you have this new position secured you will enjoy a much longer speedo-cable lifetime.

To show how it appears I sprayed some white paint over mine so the photo would be clear. Take a look.

Fran



CMI 2017 Schedule

Membership meetings are on the 2nd Tuesday of each month (unless otherwise announced)

Boards of Directors' meetings are on the last Thursday of each month (unless otherwise announced)

- April**
- 08-09 GSTA, Coliseum, State Fair Grounds (<http://www.gstarod-custom.com>)
 - 11 CMI Membership meeting – MUM (Messiah United Methodist Church, Plymouth)**
 - 15 MSRA General Membership meeting at Eisenhower Community Center, Hopkins (doors open @ 6; meeting starts at 7)
 - 27 Directors' meeting
 - 29 Pancake breakfast – Park Tavern, St. Louis Park, 9-11:00
- May**
- 07 Spring Extravaganza Car Show and Swap Meet, State Fairgrounds, 7 a.m. – 3 p.m. (www.gopherstatebuick.org)
 - 09 Membership meeting – *tbd***
 - 25 Directors' meeting
- June**
- 04 GMCCA – State Fairgrounds**
 - 13 Membership meeting – *tbd***
 - 23-25 Back to the 50's, State Fairgrounds (www.msra.com)
 - 27- July 01 CORSA convention, Independence, MO**
 - 29 Directors' meeting
- July**
- 04 Fourth of July Parade, Delano – Post Parade Picnic @ the park
 - 06-08 Iola Old Car Show and Swap Meet (Featuring Camaro)
 - 11 Membership meeting – *tbd***
 - 27 Directors' meeting
 - 28-30 Little Log House show, Hastings (<http://www.littleloghouseshow.com>)
 - 28-30 Kolacky Days, Montgomery, MN (Classic car show 7/23; 9 am-3 pm) (<http://www.montgomerymn.org/thursday-july-23/>)
 - 30 10,000 Lakes Concours d' Elegance, Excelsior (<http://10000lakesconcours.com/>)
- August**
- 08 Membership meeting – *tbd***
 - 12 New London – New Brighton Antique Auto Run (<http://www.anticquearrun.org/>)
 - 20 Pantowners Car Show, Benton County Fairgrounds (<http://www.pantowners.org/carshow.html>)
 - XX Christ's Cross Car and Craft Show, Ham Lake, MN (<http://www.christscrosscarclub.org>)
 - 24 Director's meeting
- Sept**
- 12 Membership meeting (Thursday) New Ulm Car Hop & Shop 5-8 p.m.**
 - XX Classics by the Lake, Buffalo, MN 10am – 2pm ?
 - 28 Directors' meeting



35th Annual General Motors Car Clubs Association

ALL GM CAR / TRUCK SHOW AND SWAP MEET



Live DJ playing music
Food vendors on site!
Dash plaques to first 500 show vehicles!

SUNDAY, JUNE 4, 2017 • 8 AM - 2 PM
MINNESOTA STATE FAIRGROUNDS - MACHINERY HILL

SPECTATORS

*General Admission: \$5.00/Adult
*Children under 12: FREE

EVENT INFORMATION

www.gmcca.com
www.facebook.com/GMCCAssociation

***STATE FAIR RULES PROHIBIT:
OPEN FIRES, BBQ's AND
ALCOHOLIC BEVERAGES.
PETS ON LEASHES ONLY**

PARTICIPANT AWARDS FOR

**BUICK • CADILLAC • CHEVROLET • CORVAIR • CORVETTE • CAMARO • CHEVELLE • NOVA
OLDSMOBILE • PONTIAC • SATURN /OTHER GM • CHEVROLET/GMC TRUCKS**

Show Vehicles: Gates open at 7am - Enter at intersection of Larpenteur Ave & Underwood.

For Sale Vehicles: Gates open at 7am - Enter at intersection of Larpenteur Ave & Underwood.

Pre-register for guaranteed space (until 10AM) & reduced entry fee.

Swappers: Gates open at 6am - Enter at Snelling Avenue Main Gate - All Makes of auto parts are welcome!

Spectators: Gates open at 7am to the show/swap area.

Please print legibly or use address label

REGISTRATION FORM

Name _____

Street _____

City _____ State _____ Zip _____

Phone () _____

Car Club Affiliations (if any) _____

GM SHOW VEHICLE

Make _____ Year _____

Model _____

Preregister before May 15th - \$10 per vehicle

Register after May 15th - \$15 per vehicle

Includes Car, driver & one passenger per admission.

SWAP SPACE - 15'x 20' Space

\$10 each preregistered before 5/15

\$15 each after 5/15

FOR SALE AREA VEHICLES (All Makes)

\$15 per vehicle preregistered before 5/15

\$20 per vehicle after 5/15

NO 'For Sale' signs allowed in the show area

**Make checks payable to and send
pre-registration form to: GMCCA
9632 Wyoming Terrace
Bloomington, MN 55438**

The 45th Annual Twin Cities Auto Show was held at the Minneapolis Auditorium this March. CMI held the monthly General Membership Meeting there and the Auto Show was the Tech Session! The 10,000 Lakes Concours d' elegance provided a nice array of vintage display cars as well, on the 2nd level. We even saw the Lego Batmobile!

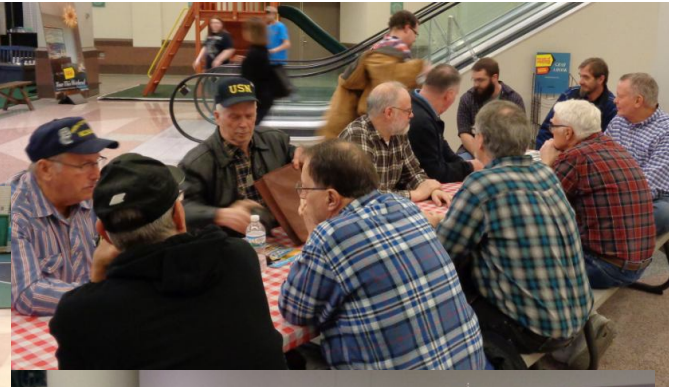

Adjusting the lash in your Sector shaft, with your own wrench

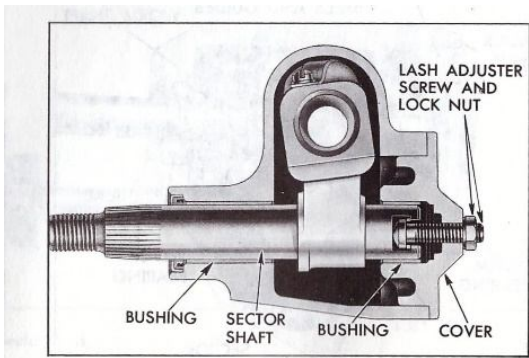

Fig. 4—Sector Gear and Pitman Shaft

CORVAIR SHOP MANUAL

First off let's look at what is; the Sector box that houses the sector shaft which connects to the pitman arm that moves the relay rod back and forth.

The diagram from the shop manual is a good place to start. It clearly shows the screw that I am talking about. The screw moves the sector shaft to engage the teeth on its shaft to the teeth on the ball-nut. When properly adjusted the ball-nut and the sector shaft have ZERO clearance



between the two – giving you a nice tight control of your “straight-ahead” steering. You can access the working end of this screw, in the trunk, by picking out the plastic plug down in front of the Brake Master Cylinder.



With the plug removed you can see the screw in the middle of the hole. The screw is secured by a half inch nut. To turn the screw, you must release the grip of that nut...and when you turn the screw the nut turns with it, making the adjustment a little complex. A device that will hold the nut, while you turn the screw, would be nice. I didn't have one till today. I was adjusting my lash and found the lock-nut to be quite snug. I had to 'wrench' it loose. This obviously turned the screw, when I turned that snug nut. Now I needed a tool to hold the nut while I turned the captured screw.

Here's what I did.

I looked on my shelf for a half inch box-end wrench that could stand a modification, and torched it just enough to get the bend close enough to the box so that the tool could fit down in that hole in the floor. Once I had the box in position, I put a kink in the handle of the wrench so I could use it where I wanted to.

Now I have a wrench to use whenever I want to adjust the lash of my sector shaft! A WHITE one!

Fran



CMI Classifieds

Corvair Owner's Manuals: 1965, 1967 (2), 1968 (2)
 Corvair Shop Manuals: 1960, 1962 plus Supplement,
 1965, 1966, 1968
 Corvair P&A Catalog: 1960-1969 (one manual)

It's been a while since I physically checked on them but last I did, that's what was there. If someone has interest, I'll verify I still have them. All are originals - no repros. They've been stored in boxes and file cabinets over the years, so they're in really good condition. Ron

If interested, contact Chuck Johnson by email (cljohnson99@gmail.com) or at our Monthly meeting.

For Parts: 3 lates, 2 coupes and 1 convert. Probably too much rust to restore, but they may have the part you need. Contact Rich Storlie storlieaircooled@yahoo.com

1965 Monza 110 4 door automatic. Blue Bucket seats. About 55 thousand miles. We (dad) is second owner. Bought for elderly lady around 1975. Ran when it was last parked around 10 years ago. Needs brake work now as peddle goes to floor. All original with very little rust. Would not take much to get it road worthy. Asking \$1900 or BO. 651-436-5565 Rick



John Colton (owner)
 39374 Grand Ave., North Branch, MN 55056
johnny@ircustomplating.com

New: Engine electrical harness, ball joints, Pertronix ignition; headers (110 and 140); custom exhaust; Wallen rebuilt starters generators and alternators; mufflers; rebuilt flywheels; new belly pan for late; crank and rod bearings.

Used parts: complete engines, transmissions, differentials: call for parts – I have a large inventory.

Also: 1969 110hp engine (runs great, sealed & pretty) Rare – aftermarket tube style early air grill – Solid flywheel

I also offer full time Corvair repair

Gary Nelson 612-644-1258

1965 CORSA 4sp, 2dr <SHOW QUALITY – ed.>
 Complete Restoration, factory A/C ('66 style),
 Black/black \$18,000 Hill Sweet 952-926-7803



1967 Monza coupe, family owned for almost 50 years. Stored inside all seasons and I do not drive it on wet roads or chemically treated roads. The odometer says about 117,000. New carpet and seat covers and repainted. Documentation from original purchase to current. Asking \$12,000. Greg Helm helmster@integra.net or my home phone 952-447-6495 Savage



Corvair Repair In Minnesota

Your Place or Mine
 Part Time Casual, Off Season Is Best
 Mobile Service, Trailing Service, Reasonable Rates
 CORSA, Corvair Minnesota and SCCA Member

Jim Brandberg

2214 - 293 1/2 Av. NW, Isanti, MN 55040
 763-444-9334 jimbrandberg@aol.com

CMI Classifieds- cont.

1964 MONZA convertible

Palomar Red/ White top; Powerglide; twin carburetor; original wheel covers; dual mirrors; good interior; bucket seats; new Am/Fm radio/ MP3 Boss audio system; slight valve cover oil leak; everything works except heater. 608-444-9589 CJQUAGUSNA@gmail.com \$5750.



1963 Monza 110 Engine 4 speed, was running when put in storage, we have title, need to have key made. The car is located in Rogers, MN. \$2,000 obo. Ron Lucas 763-242-4090; 763-226-8440; 763-420-2569 lorrainelucas7@gmail.com



1962 Monza Coupe- Slightly over 42,000 miles, runs well, no rust, in very good condition. Automatic transmission, four new tires. White with black interior. Fun to drive but at my age it's getting tougher to get in and out! Make offer Bill Von Hassel 952-946-2245 or VonH9700@aol.com



1964 Monza Spyder. Turbo/ 4 speed with 49,000 original miles. The car is mint! Call with questions or to see the car. Burt Rovner 763-286-2075 burt.rovner@gmail.com



WEBSITE: <http://www.corvaairminnesota.com/>

OFFICERS:

PRESIDENT

Jack Bacon
195 Mallard Lane
Loretto, MN 55357-9523
763.479.6214
jackchrisbacon@hotmail.com

TREASURER

Lee Knauf
401 West Street
New Ulm, MN 56073-1527
952.448.6983
vairy69@comcast.net

VICE-PRESIDENT

Jim Becker
12930 37th ST
Clear Lake, MN 55319-1101
320-743-2889
mr.jebecker@gmail.com

SECRETARY

Chuck Johnson
9632 Wyoming Terrace
Bloomington, MN 55438-1640
952.240-0414
cljohnson99@gmail.com

MEMBER COORDINATOR

Jack Bacon
195 Mallard Lane
Loretto, MN 55357-9523
763.479.6214
jackchrisbacon@hotmail.com

COORDINATORS:

TECHNICAL EDITOR

Fran Schmit
3370 Library Lane
St. Louis Park, MN
55426-4224
952.929.9174
schmfran@hotmail.com

CLUB WEAR

Bill Cook
600 10th St S
Buffalo, MN 55313-5025
612.940-9179
wdcacook@yahoo.com

HISTORIAN

Cara Knauf
401 West Street
New Ulm, MN 56073-1527
952.448.6983

EDITOR

John Herkenratt
408 7th St S
Hopkins, MN 55343-7722
Jherken1@netzero.net



April showers!

Spot a 'Vair



October 26 1970 in Orange, Massachusetts: Erwin Stockwell, 62, who has flown for 37 years, "pilots" his aeromobile, a standard car with wings, propeller and an extra engine added, down the runway of Municipal Airport on a trial run. Stockwell, retired precision tool maker, assembled his vehicle behind his home with federal Aviation Administration approval. He hopes to have his invention ready for flight this spring.

.....

CMI is a non-profit corporation, chartered with The CORVAIR Society of America. Send CORVAIR Minnesota's \$20.00 annual dues, payable by Jan 01, to the CMI Treasurer. Membership in CORVAIR Minnesota entitles you to the monthly newsletter, "The Leeky Seel", with free ads for members, a club window sticker, discounts on club activities, information on parts availability, and good advice on the preservation and enjoyment of the CORVAIR automobile.... Yeah!

THE LEEKY SEEL

3370 Library Lane
St. Louis Park, MN 55426-4224
TEMP - RETURN SERVICE REQUESTED



*See you at the MUM
Last chance for DUES!*